

DIRECTFLO® PERFORMER SERIES



DP200 POLYPROPYLENE AND ALUMINIUM DIAPHRAGM PUMPS. 200 L/MIN

555 164 / 555 030

Very reliable diaphragm polypropylene or aluminium pumps for large volume transfer (200 l/min max.), dosing, and dispensing a variety of fluids.

POLYPROPYLENE PUMPS have a polypropylene air motor. Typical applications for these pumps are transferring and dispensing of windshield wash and antifreeze solutions and AdBlue®/DEF.

ALUMINIUM PUMPS have an aluminium air motor. Typical applications for these pumps are transferring and dispensing of antifreeze solutions, lubricants and diesel, and waste oil evacuation.

They can be used as stand-alone pumps for transfer applications or as systems pumps in distribution systems that include hose reels.

Pump inlet and outlet ports can be mounted in different positions for increased installation versatility.

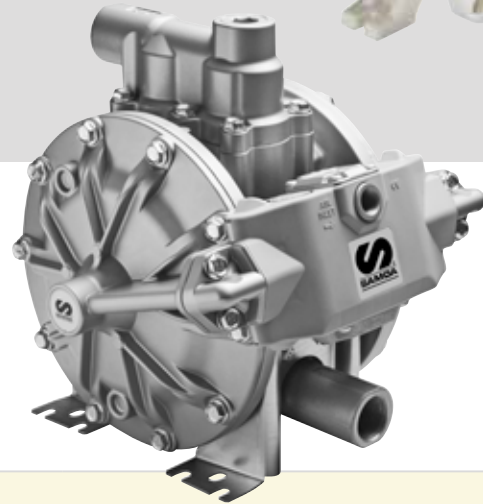

03

OTHER FLUIDS PUMPS

FLUIDS HANDLED

- Antifreeze and antifreeze solutions
- AdBlue® / DEF
- Lubricants
- Waste oil
- Diesel

MARKETS SERVED

- Service shops
- Car and truck dealers
- In plant
- Agriculture
- Lube trucks
- Mining and construction
- Railroad and mass transit

MODELS						
PART No.	PUMP BODY	DIAPHRAGMS	BALLS	SEATS	OTHER WETTED MATERIALS	APPLICATIONS
555 164	Polypropylene	Hytrel®	PTFE	Polypropylene	Viton®, Stainless steel	Antifreeze and windshield wash solutions, Ad Blue®/DEF.
555 010	Aluminium	Hytrel®	Acetal	Hytrel®	Viton®, Stainless steel	Antifreeze solutions
555 030	Aluminium	Buna-N	Acetal	Buna-N	Stainless steel	Lubricants, diesel, waste oil evacuation and transfer

Tested at room temperature, with water and flooded pump with 800 mm (31.5 inches) height of water above the pump inlet.

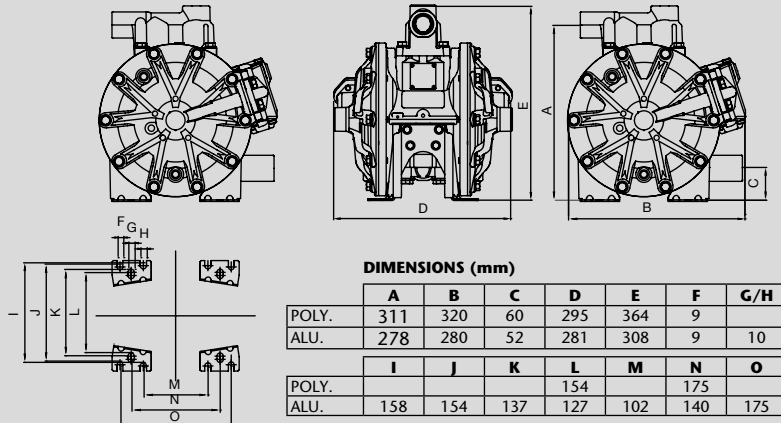
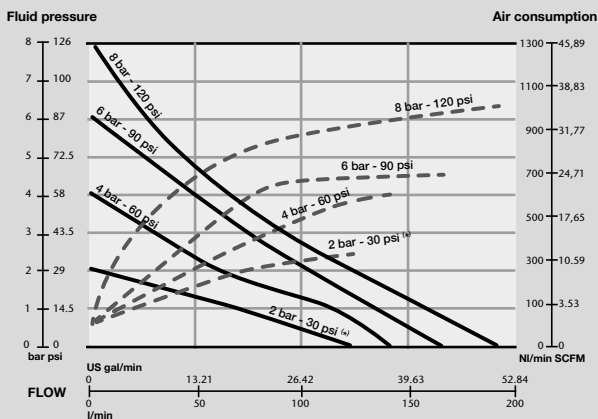

DIMENSIONS (mm)

	A	B	C	D	E	F	G/H
POLY.	311	320	60	295	364	9	
ALU.	278	280	52	281	308	9	10
	I	J	K	L	M	N	O
POLY.				154		175	
ALU.	158	154	137	127	102	140	175

(* 2 bar test with a PTFE (Teflon®) diaphragms pump.

— Outlet pressure
- - - Air consumption