

554 010

DF250 ALUMINIUM DIAPHRAGM PUMPS. 250 L/MIN

Very reliable diaphragm aluminium pumps for large volume transfer (250 l/min max.), dispensing and evacuating a variety of fluids.

These pumps have an aluminium air motor. Typical applications for these pumps are transferring and dispensing of antifreeze solutions, lubricants and diesel, and waste oil evacuation.

They can be used as stand-alone pumps for transfer applications or as systems pumps in distribution systems that include hose reels.

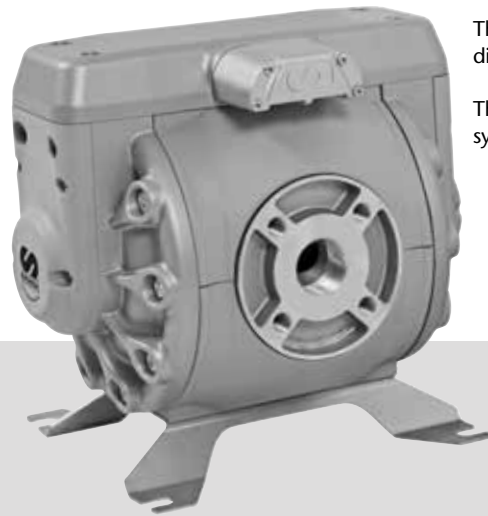

FLUIDS HANDLED

- Antifreeze and antifreeze solutions
- Lubricants
- Waste oil
- Diesel

MARKETS SERVED

- Service shops
- Car and truck dealers
- In plant
- Agriculture
- Lube trucks
- Mining and construction
- Railroad and mass transit

03

OTHER FLUIDS PUMPS

| MODELS | | | | | | |
|----------|-----------|------------|---------|-----------------|-----------------------|---|
| PART No. | PUMP BODY | DIAPHRAGMS | BALLS | SEATS | OTHER WETTED MATERIAL | APPLICATIONS |
| 554 010 | Aluminium | Hytrel® | Hytrel® | Stainless steel | Viton® | Antifreeze solutions |
| 554 030 | Aluminium | Buna-N | Buna-N | Stainless steel | - | Antifreeze solutions, lubricants, diesel, waste oil evacuation and transfer |

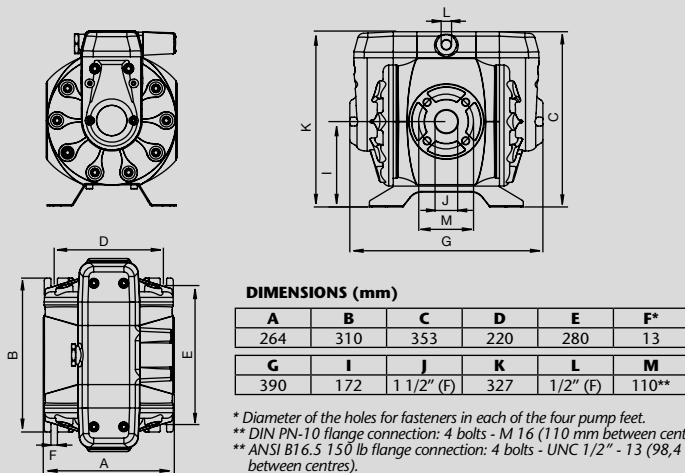

Tested at room temperature, with water and flooded pump with 800 mm (31.5 inches) height of water above the pump inlet.

